

Edited by Bill Travis and Anne Watson Swager

## Potentiometer tames current-feedback op amp

Leslie Green, Gould-Nicolet Technologies, Ilford, Essex, UK

THE CIRCUIT IN **Figure 1a** includes a potentiometer in series with the inverting input of a current-feedback op amp. With a voltage-feedback op amp, a potentiometer in series with the inverting input would serve no useful function. However, with a current-feedback amplifier, the potentiometer controls the bandwidth without changing the gain. The function of this potentiometer is similar to a capacitor,  $C_p$ , in parallel with the feedback resistor of a voltage-feedback op amp (**Figure 1b**).

In **Figure 1a**, feedback resistor  $R_1$  strongly governs the bandwidth and pulse-response characteristics of the current-feedback amplifier. However, changing  $R_1$  also changes the gain. Thus, you have to change both  $R_1$  and  $R_2$  to adjust the pulse response while keeping the gain constant, which makes the design considerably difficult to adjust. The inclusion of the potentiometer allows you to adjust the pulse response independently of the

**Figure 1**

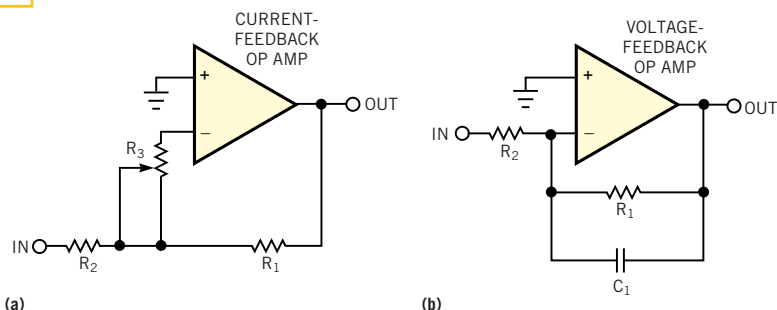

A potentiometer,  $R_3$ , allows you to adjust the bandwidth of a current-feedback op amp without changing the gain (a).  $R_3$  performs the same bandwidth-control function as  $C_1$  does for a voltage-feedback op amp (b).

gain, which makes the potentiometer a useful control.

Current-feedback amplifiers are available with closed-loop bandwidths much greater than 500 MHz, and they oscillate or give poor pulse responses if you wire them with 2-in. leads on all components and fail to use proper decoupling. You need skill to properly lay out these devices. However, using normal UHF circuit skills and the trick in **Figure 1a**, you can easily control these devices.

A typical value for the feedback resistor when using a current-feedback amplifier is approximately 150 to 900 $\Omega$ . The nominal value of the potentiometer,  $R_3$ , is 50 to 500 $\Omega$ .

If you look at the manufacturers' specified time-domain, or pulse, response of current-feedback amplifiers, you may feel that the response is not flat enough for your application. Some data sheets show poor figures for overshoot and ringing. However, using **Figure 1a**'s circuit, you

can tune the response of the amplifier within a system to give acceptable performance. You can also put a capacitor across  $R_3$  to modify the response of the amplifier. These modifications are sometimes necessary to get the best response from an amplifier or a system. It is also not unusual to have to correct for an error that occurs in another stage.

The main signal path of an oscilloscope is a demanding application for an op amp due to the requirement for high bandwidth and excellent pulse response. However, the scheme in **Figure 1a** was useful in the design of the main ADC buffer amplifier of the 150-MHz Gould DataSYS 840 DSO. The design uses an HFA1130 current-feedback op amp and an  $R_3$  value of 100 $\Omega$  to adjust the overall bandwidth of the oscilloscope. (DI #2524)

TO VOTE FOR THIS DESIGN,  
CIRCLE NO. 343

Potentiometer tames current-feedback op amp .....	177
Cable finder seeks out wall conduits .....	178
Electronic transformer dims halogen lamp .....	180
Low-cost, programmable oscillator operates at 2 GHz.....	182
Ring-tone generator uses high-Q filter .....	184
Simple circuit produces a less-than-25-nsec pulse.....	188
$\mu$ C multiplexes six digital potentiometers .....	190

# Cable finder seeks out wall conduits

Luis Miguel Brugarolas and Manuel Ramón,

Sire Sistemas y Redes Telemáticas, Tres Cantos, Madrid, Spain

**W**HEN YOU DEBUG home electrical wiring, a tool that determines the location of cable conduits comes in handy, especially when problems arise. Some tools, such as nylon or glass fiber guides, contain small magnets and compasses that act as sensor elements. These short-range systems are useful for brick walls, but not for other wall-mounting systems that include iron elements. Some electronic aid would be helpful.

The circuit in **Figure 1** uses an antenna in the wall conduit and a receiver to locate a cable conduit. The combination can accurately locate the antenna placement. The simplest and cheapest approach is to use a portable AM radio, which includes a ferrite antenna with excellent directivity and sufficient range of a few centimeters for good resolution.

The circuit uses a relaxation oscillator with an adjustable frequency to apply current pulses to a twisted-pair cable. This oscillator has the AM-broadcast range of 530 to 1600 kHz. A lower frequency oscillator switches these pulses on and off. The envelope detectors of AM radios can easily detect the pulses. Howev-

er, the circuit requires an additional refinement because pure tones are unpleasant. Thus, some modulation is necessary. This circuit allows for dual tones, such as a police siren, or sweeping tones, such as an ambulance siren, using a switch. The circuit provides dual-tone operation using a bipolar transistor that shorts a capacitor on and off in the capacitive section of the oscillator path. The sweeping tone is a mixed AM/FM format that the circuit produces by biasing the relaxation oscillator with a triangular signal from a lower frequency oscillator. This bias changes the threshold level of the modulating tone, which produces modulation of the fundamental frequency and the aspect ratio of the output.

A regulated power source biases the oscillator section to minimize the high-frequency oscillator's voltage sensitivity. A current source, which is insensitive to supply voltage, controls the final stage. This control, instead of a direct connection to the supply voltage, provides some protection in the event of a short circuit and provides similar output independently of the antenna resistance. The LED,

which the circuit uses as a voltage reference, also indicates circuit activity. The supply voltage can vary from 7 to 12V or higher if you take care of the BD140 transistor's dissipation requirements.

To use the circuit, switch on an AM receiver and find a position without broadcast stations. Place the receiver close to the generator, switch on the circuit, and adjust the variable resistor until the tone is audible. Move the receiver to find the direction of better sensitivity. Then, use the radio receiver to find where the twisted-pair cable goes.

Beware that this circuit produces EMI not only in the AM-broadcast range, but also over a wide frequency range due to the high harmonic content of the generated signals. The use of twisted-pair cable reduces the amount of interference in the far-field region. Therefore, use the circuit cautiously, and disconnect the circuit as soon as you locate the cable. (DI #2523)

TO VOTE FOR THIS DESIGN,  
CIRCLE NO. 344

**Figure 1**

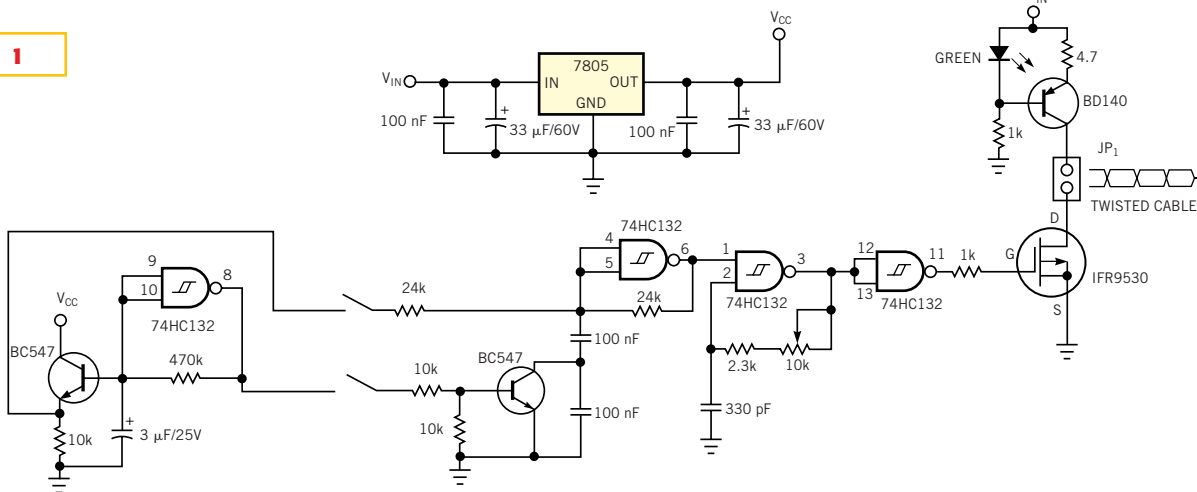

To discover the location of cable conduits, a relaxation oscillator applies current pulses to a twisted-pair cable, and an AM radio functions as a receiver.

# Electronic transformer dims halogen lamp

Robert Magdziak, Warsaw, Poland

**A** TYPICAL, SWITCHED-MODE power supply for a halogen lamp, commonly known as an electronic transformer, is a clever and simple device. However, it has some limitations, such as its inability to dim the lamp. **Figure 1** shows a simplified schematic of a typical low-voltage halogen-lamp transformer without the protection circuits and EMI filter.  $Q_1$  and  $Q_2$  with  $C_2$  and  $C_3$  comprise a classic, half-bridge topology that works in self-oscillating mode. The circuit provides positive feedback by placing the primary windings of transformer  $T_1$  in series with the bridge output. To achieve a high power-factor value, a rectified but unfiltered mains voltage supplies power to the circuit. The working frequency is approximately 30 to 40 kHz.

This simple circuit does not allow for correctly and conveniently dimming the lamp because any attempts to manipulate the time constant of the  $R_1/C_1$  start-up circuit worsen the power factor. A possible solution that involves making taps in the primary winding of transformer  $T_2$  is neither elegant nor convenient.

The circuit in **Figure 2** provides a way to dim the lamp. In this circuit, a popular PWM IC controls a modified buck regulator. One modification is a change in the position of  $Q_1$ , which lets you control the regulator without using a pulse transformer, for example. A second modification significantly reduces the capacity of  $C_1$  because the circuit should act similarly to an autotransformer to keep a high power factor. Therefore, the rectified mains voltage powers the regulator, which sits behind the bridge rectifier. The regulator produces the same output-voltage shape but of lower and regulated amplitude.  $C_1$  has a low value, so, in conjunction with  $L_1$ ,  $C_1$  removes any switching products from the output voltage without filtering out 100-Hz ripples of the mains voltage.

Thus, the circuit is halfway between a buck regulator and a current source feeding an H-bridge converter. Using a classic current source to feed the bridge con-

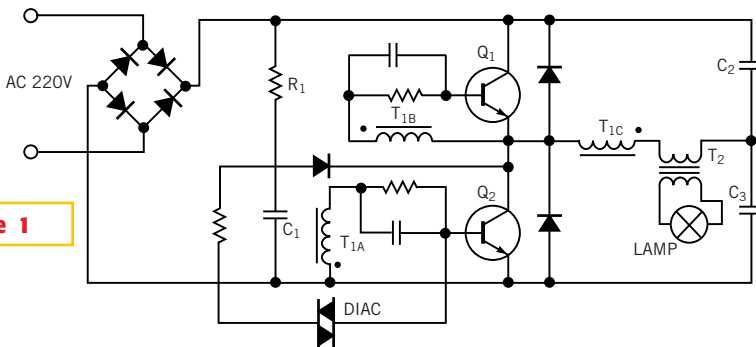

**Figure 1**

A typical low-voltage halogen-lamp transformer provides no lamp-dimming capability.

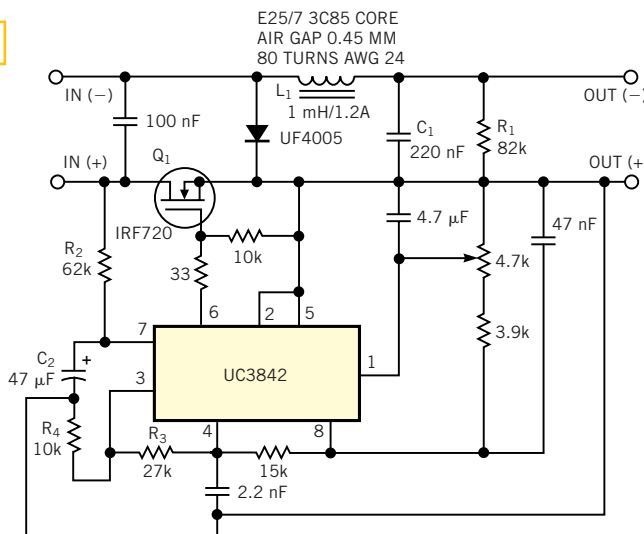

**Figure 2**

A simple PWM IC controls the duty cycle of  $Q_1$ , which dims or brightens the lamp.

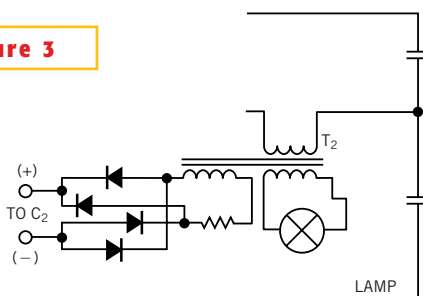

**Figure 3**

To keep the UC3842 IC running requires extra power to  $C_2$ , which secondary windings on  $T_2$  and a bridge rectifier can provide.

verter would be inconvenient because of the lamp power supply's self-oscillating mode and variable switching frequency.

Changing the duty cycle of  $Q_1$ 's pulses accomplishes the lamp dimming. You can use any one of many integrated PWM controllers to control the switching of  $Q_1$ . The only important point is that the PWM IC needs to work with the maximum pulse duty cycle, which is important if you want to keep the brightness of the

halogen lamp close to maximal. The prototype uses a cheap controller, the UC3842, which operates in voltage mode because of the presence of the  $R_3/R_4$  divider.

To operate the circuit, you need to supply the controller. On power-up,  $C_2$  charges through  $R_1$  and  $R_2$ , which starts the switching. To keep the controller running requires extra power to  $C_2$ . The

additional, secondary windings on  $T_2$  and the bridge rectifier support this function (**Figure 3**). Unfortunately, the core choke,  $L_1$ , can have no secondary windings because those windings can't supply enough power to the controller under maximum-duty-cycle conditions.

After adding an EMI filter and bridge rectifier to the regulator input, the circuit can work in stand-alone mode. With the

circuit in this mode, you can connect to the output more than a few parallel ready-made electronic transformers without making any changes. In such a case, you need to recalculate the values and types of power components according to the power load. (DI #2525)

TO VOTE FOR THIS DESIGN,  
CIRCLE NO. 345

## Low-cost, programmable oscillator operates at 2 GHz

*A Navarro, M Rostami and J N Matos, Instituto de Telecomunicações, Aveiro University, Portugal*

**A**LL WIRELESS COMMUNICATION systems need a local oscillator. **Figure 1** shows a low-cost PLL circuit for the 2-GHz band for such applications as industrial, scientific, and medical (ISM) and satellite personal-communication systems (S-PCS). The central IC in the circuit is the LMX2325 (National Semiconductor, [www.national.com](http://www.national.com)) frequency synthesizer, which features RF operation to 2.5 GHz. This IC incorporates an N-programmable divider and a phase comparator. The JTOS-3000P (Mini-Circuits) VCO constrains the oscillation frequency to 2.3 to 2.5 GHz. The VCO's tuning-voltage range of 0 to 5V is compatible with the internal charge-pump D0 output of the LMX2325. The COP8SAA7  $\mu$ C

programs the synthesizer's internal registers. You can calculate the register values using the program LMX2325.EXE (National Semiconductor). The values depend on the desired oscillation frequency, the external crystal, and the reference-frequency values.  $R_1$ ,  $C_1$ , and  $C_2$  implement a second-order loop filter, and you can determine the component values using the LOOPFILT.EXE (National Semiconductor) program. The values depend mainly on the oscillation frequency and the VCO tuning sensitivity.

$R_2$ ,  $R_3$ ,  $R_4$ , and  $L_1$  form a T-network. The design in **Figure 1** assumes that a 50 $\Omega$  load connects to ac-coupling capacitor  $C_3$ . The T-section matches the syn-

thesizer  $F_{IN}$  pin's input reactive impedance of 40-j $\omega$  to the 50 $\Omega$  output impedance of the VCO's RF OUT pin and output load. If  $f$  is the oscillation frequency in hertz,  $X$  is approximately equal to  $(-36 \times 10^{-9})f + 162$ . Therefore, the following inductor value for  $L_1$  cancels the reactance:

$$L = \frac{9}{\pi} \left( \frac{9}{f} - 2 \times 10^{-9} \right)$$

You must place the matching network components close to each other on the pc board. A power supply with good regulation characteristics is necessary, and, therefore, you should use a 7805 IC on the pc board.

A prototype of **Figure 1**'s circuit operating at  $f = 2.45$  GHz has an output power of 7 dBm and a phase noise of -75 dBc/Hz at a 10-kHz offset. You can download the source program for the  $\mu$ C from EDN's Web site, [www.ednmag.com](http://www.ednmag.com). Click on "Search Databases" and then enter the Software Center to download the file for Design Idea #2526. You can then use the previously mentioned support software ([www.national.com/cop8/](http://www.national.com/cop8/)) or use the .hex file. (DI #2526)

**Figure 1**

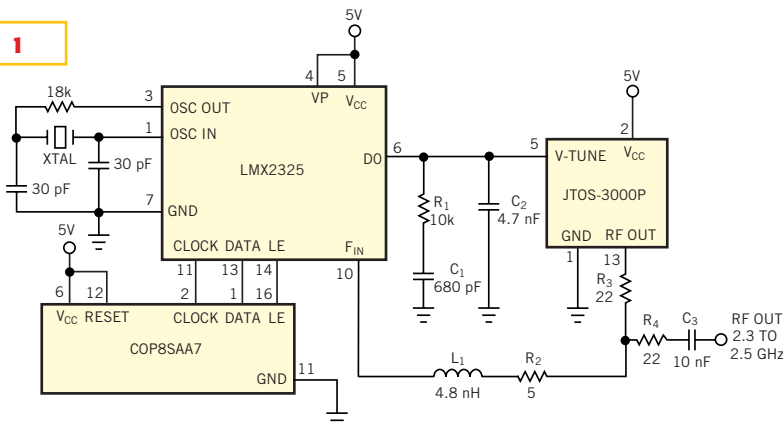

An LMX2325 frequency-synthesizer IC, a JTOS-3000P VCO, and a COP8SAA7  $\mu$ C create a low-cost, programmable oscillator for 2-GHz wireless applications.

TO VOTE FOR THIS DESIGN,  
CIRCLE NO. 346

# Ring-tone generator uses high-Q filter

Jonathan Celani, Linear Technology Corp, Milpitas, CA

**M**ODERN TELEPHONE applications need to generate a high-voltage sine wave to use as a ring-tone signal. Several familiar design alternatives generally involve either an IC-controlled flyback-type scheme or a ringer-module-“brick” approach. Unfortunately, module approaches are expensive, and flyback circuits are generally complicated and have inherent harmonic-suppression issues. The design parameters of both these approaches are generally fixed and offer little flexibility for users.

A simple yet effective method for producing a high-quality sine wave is to place a high-Q bandpass filter in a positive-feedback loop with a hard-limited gain element. This scheme produces a sine wave at the bandpass frequency,  $\omega_o$ , at the filter output. This signal drives the input of the hard-limiter, which produces a square wave at the same frequency. Limiting voltage levels control the amplitude of this square wave. The limiter’s output feeds back to the input of the bandpass filter, which completes the loop. The overall circuit produces a sine wave of fre-

quency  $\omega_o$  with an amplitude that corresponds to the filter gain,  $|H_o|$ , times the amplitude of the fundamental component of the square wave. This type of circuit is easy to produce using a couple of inexpensive ICs. The trick, however, is translating the IC-generated sine wave into a high-voltage signal suitable for ringing telephones.

The ring-tone generator in **Figure 1** configures an active-filter IC, the LT1684, as a high-gain, high-Q bandpass filter in a positive-feedback loop with a controlled-output comparator. This configuration produces a high-voltage, high-quality sine wave at the filter output. You can adjust amplitude and frequency characteristics by simply changing a few resistor values. The output of the LT1684 is internally current-limited to a minimum of  $\pm 100$  mA, so load capacity is variable based on programmed peak-output amplitude. The LT1684 employs an active-tracking supply technique that provides a versatile and simple approach to the ring-tone problem. This technique comprises two high-voltage MOSFET

source-followers that provide power for the IC. The MOSFETs function as power-supply level-shifters, bootstrapping the supply pins of the IC about the output of the active filter element. This scheme effectively suspends the IC between the MOSFETs, allowing the IC to output a voltage far exceeding its own supplies. The voltages across the MOSFETs themselves are the only limit to the IC’s output-voltage capability. This supply-bootstrapping technique enables linear generation of a high-voltage output signal and takes advantage of the intrinsic supply-noise immunity of a linear amplifier, reducing the need for large high-voltage filtering elements.

The ring-tone generator’s hard-limited gain element uses the LT1684’s controlled-output receiver/ buffer to limit the output of a comparator. The circuit bootstraps an LT1017 dual-comparator IC along with the LT1684 to provide voltage gain and to provide the differential control signals that the LT1684 receiver/ buffer needs.

The active-bandpass-filter circuit uses

**Figure 1**

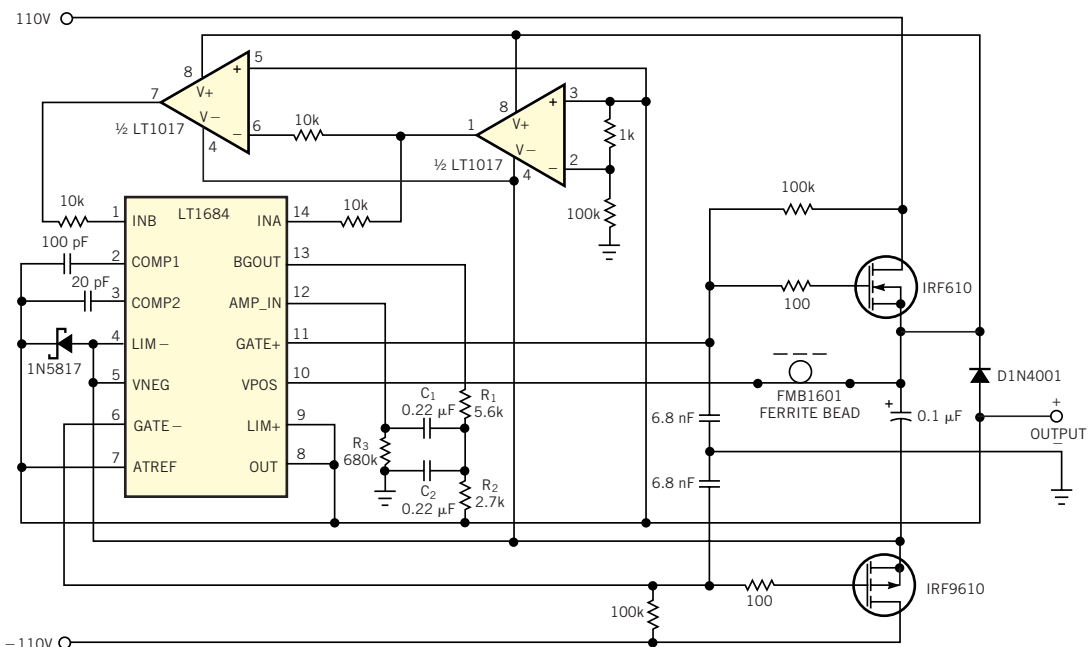

An active-filter IC, the LT1684, and a pair of MOSFETs produce a high-voltage, high-quality sine wave at the output.

a basic single-amplifier, multiple-feedback configuration using  $R_1$ ,  $R_2$ ,  $R_3$ ,  $C_1$ , and  $C_2$ . However, the active-tracking supply technique of the LT1684 requires some modifications to the standard topology (**Figure 2a**). The modifications include swapping the amplifier's signal polarity, referencing all signals to the output, and referencing all feedback elements to ground. **Figure 2b** shows the modified multiple-feedback bandpass filter. The transformed multiple-feedback bandpass-filter design equations are the same as those of a standard topology. If both capacitors are the same value ( $C_1=C_2$ ), the design equations that define the filter resistor values are as follows:

$$R_1 = \frac{Q}{\omega_0 \cdot C \cdot |H_0|}$$

$$R_2 = \frac{Q}{(2Q^2 - |H_0|)(\omega_0 \cdot C)}$$

**Figure 2**

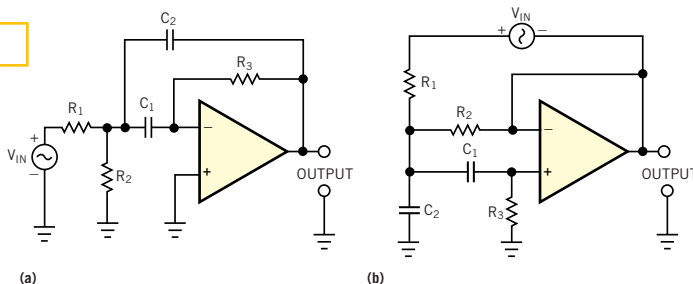

The active-tracking multiple-feedback bandpass filter in **Figure 1 (b)** involves some modifications to the standard version (a).

$$R_3 = \frac{2Q}{\omega_0 \cdot C}$$

As a design example, consider that you want to construct a ring circuit that yields a sine wave with a peak amplitude of 95V (7-REN load capability), a ring frequency of 20 Hz, and a bandpass Q of 9.4. A square wave with peak amplitude A has a fundamental component with an

amplitude of  $4A/\pi$ . This value corresponds to an LT1684 buffer/receiver output, which has a limit of  $\pm 1.25V$ . Thus,  $A=1.25V$ . Now, the desired filter's bandpass gain is

$$|H_0| = \frac{95}{(4 \cdot 1.25/\pi)} \approx 60.$$

Given capacitor values of  $0.22 \mu F$ ,  $Q=9.4$ ,  $|H_0|=60$ , and  $\omega_0=2\pi(20 \text{ Hz})$ ,

**Figure 3**

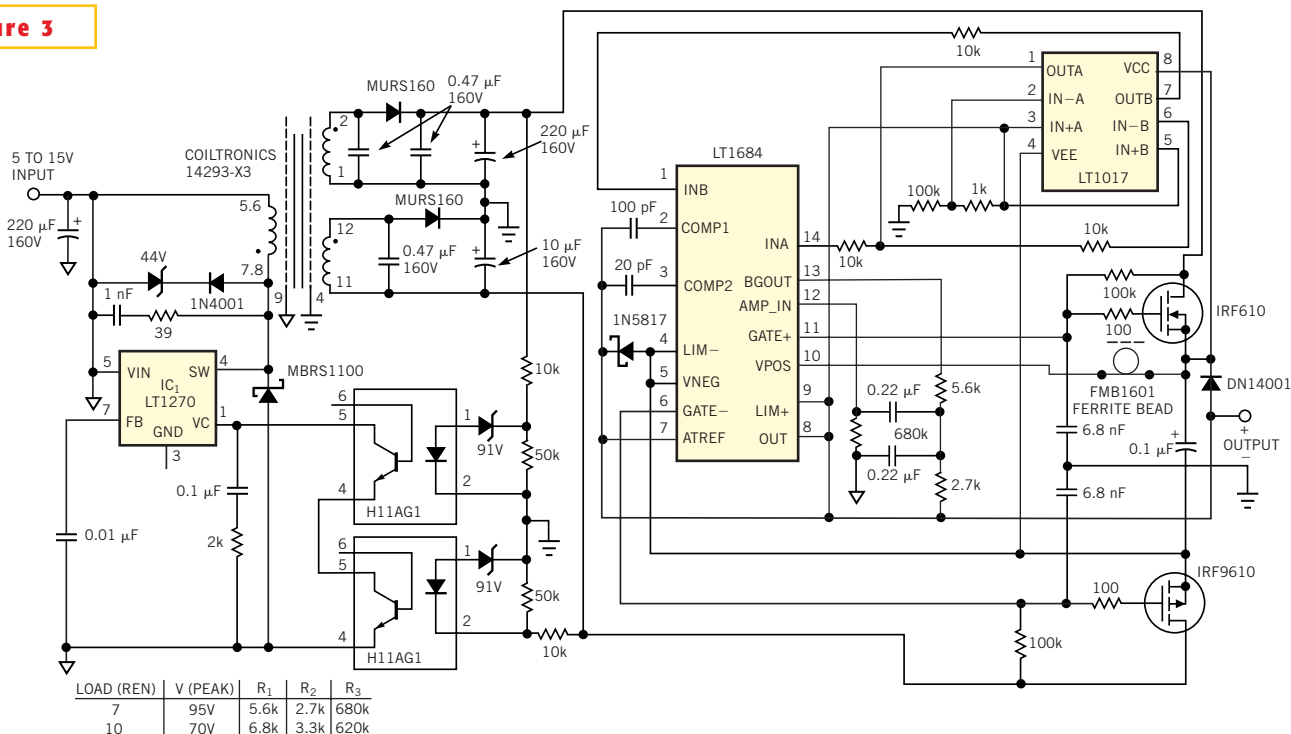

A dc-to-ring-tone converter combines the circuit from **Figure 1** with a high-voltage power supply.



you can calculate  $R_1=5.6\text{ k}\Omega$ ,  $R_2=2.7\text{ k}\Omega$ , and  $R_3=680\text{ k}\Omega$ .

You can describe many telephone-ringer modules as dc-to-ring-tone converters. A dc power supply provides power, and the output is a high-voltage sine wave. Most of these modules also offer ground-path isolation between the supply input and the ring-tone output. You can construct a circuit that mimics these attributes by coupling an isolated, high-voltage, dual-output power supply with

the LT1684/LT1017 resonant ringer circuit of **Figure 1**.

Due to the ripple rejection inherent in an op amp, the power supply requires little output filtering. Thus, you can use a relatively simple supply. The ringer circuit generates a supply load that is unbalanced, however, because the circuit imposes the low-frequency ring signal across the system load. Thus, the supply must have well-controlled cross-regulation to prevent excessive output-voltage

variations during normal operation. The dc-to-ring-tone-converter circuit in **Figure 3** uses a high-voltage power supply built around IC<sub>1</sub>. This supply uses a dual-feedback scheme that regulates on the loaded output and uses capacitor-coupled secondary windings to limit the voltage excursions at the supply outputs. (DI #2527)

TO VOTE FOR THIS DESIGN,  
CIRCLE NO. 347

## Simple circuit produces a less-than-25-nsec pulse

Andy Brandenberger, National Instruments, Austin, TX

**I**N MANY TESTING situations, a circuit that can produce a short pulse is useful. You can use a short pulse to test trigger or interrupt-pulse-width requirements and to mimic glitches or noise on inputs, for example. In some cases, short pulses with long delays between them are desirable. For these cases, a function gen-

erator is inadequate because you can reduce the duty cycle low enough to produce low-nanosecond pulse widths only at relatively high frequencies. Although purely analog circuits can generate short pulses, input and output loading and buffering propagation delays create problems with interfacing them

to TTL-compatible circuitry.

The circuit in **Figure 1** uses two one-shot timers and a D flip-flop to create a short, TTL-compatible positive pulse when triggered with a TTL-compatible positive edge. Because the circuit is positive-edge-triggered, the only requirement for the duty cycle of the triggering device is that it meets the minimum input pulse width for the one-shot timers, which is 40 nsec for the 74LS123, IC<sub>1</sub>.

IC<sub>1B</sub> provides a fixed pulse width of approximately 150 nsec. Via R<sub>1</sub>, IC<sub>1A</sub> provides a variable pulse width of 150 to 1000 nsec. A positive pulse at Input A triggers each timer. This trigger inactivates IC<sub>2A</sub>'s CLR input and makes its CK signal low. When IC<sub>1B</sub> times out, its positive-going edge clocks the logic 1 on the D input of IC<sub>2A</sub> to Output B. When IC<sub>1A</sub> times out, its output clears the Q output of IC<sub>2A</sub>, taking Output B low. Thus, you can express the pulse width at Output B as follows: Pulse width of IC<sub>2A</sub> = pulse width of IC<sub>1A</sub> + pulse width of IC<sub>1B</sub>.

The output pulse width for this circuit is variable from approximately 5 to 850 nsec. You can produce a shorter pulse width by using faster logic. The circuit also allows for easy modification should negative trigger inputs, output pulses, or both be necessary. (DI #2528)

TO VOTE FOR THIS DESIGN,  
CIRCLE NO. 348

**Figure 1**

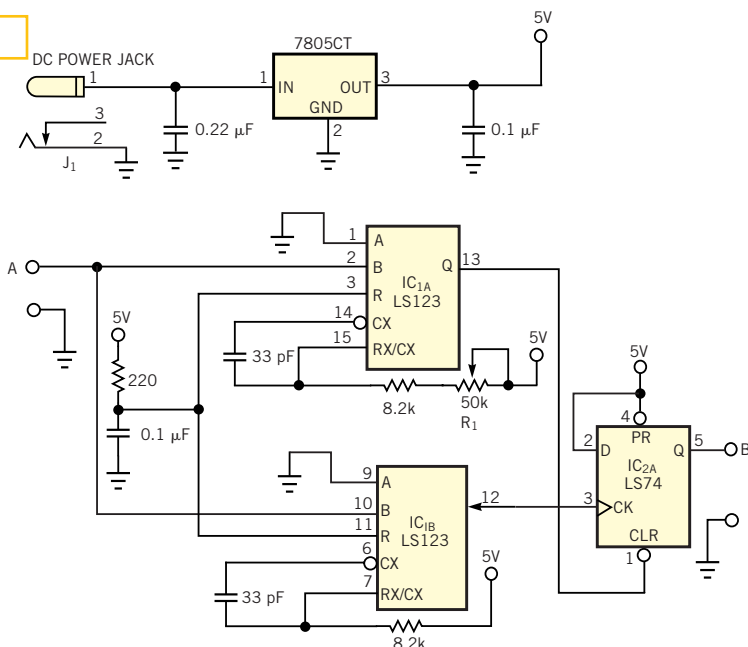

**Two one-shots and a D flip-flop comprise a pulse generator that can produce pulses of 5 to 850 nsec with a low repetition rate.**

# μC multiplexes six digital potentiometers

Ted Salazar, Maxim Integrated Products, Sunnyvale, CA

IN FIGURE 1'S CIRCUIT, a μC lets you adjust as many as six digital potentiometers. Like mechanical potentiometers, digital potentiometers can adjust regulator outputs or speaker volumes and act as rheostats. Available in resistances of 50, 100, and 200 kΩ, they let you throw away your mechanical potentiometers and the little flat-headed screwdrivers that go with them.

A DIP switch, two pushbutton switches, and IC<sub>6</sub>'s μC control the six digital potentiometers, IC<sub>0</sub> through IC<sub>5</sub> in the circuit. All of the potentiometers have a nominal end-to-end temperature coefficient of resistance of 50 ppm/°C. At power-up, each potentiometer assumes its midrange value of resistance. Each wiper connects to

one of 32 equally spaced taps along the linear-taper resistance between the H and

L terminals for that potentiometer.

Of the 13 I/O ports on IC<sub>6</sub>, Port A (A<sub>4</sub> through A<sub>0</sub>), comprises the inputs. Port B (B<sub>7</sub> through B<sub>0</sub>) comprises the outputs. To operate this manually controlled digital system, you select the desired potentiometer by setting a code via the DIP switches (Table 1) and then increment or decrement the potentiometer via pushbutton switches that connect to A<sub>1</sub> and A<sub>0</sub> (Table 2). You can obtain the μC's assembly-language program from EDN's Web site, [www.ednmag.com](http://www.ednmag.com). Click on "Search Databases" and then enter the Software Center to download the file for Design Idea #2529. (DI #2529)

**TABLE 1—DIGITAL-POTENTIOMETER SELECTION**

A <sub>4</sub>	A <sub>3</sub>	A <sub>2</sub>	Digital potentiometer
0	0	0	IC <sub>0</sub>
0	0	1	IC <sub>1</sub>
0	1	0	IC <sub>2</sub>
0	1	1	IC <sub>3</sub>
1	0	0	IC <sub>4</sub>
1	0	1	IC <sub>5</sub>
1	1	0	IC <sub>5</sub> (default)
1	1	1	IC <sub>5</sub> (default)

**TABLE 2—INCREMENT/DECREMENT CONTROL**

A <sub>1</sub>	A <sub>0</sub>	Operation
0	0	No change
0	1	Decrement selected potentiometer
1	0	Increment selected potentiometer
1	1	No change

TO VOTE FOR THIS DESIGN,  
CIRCLE NO. 349

**Figure 1**

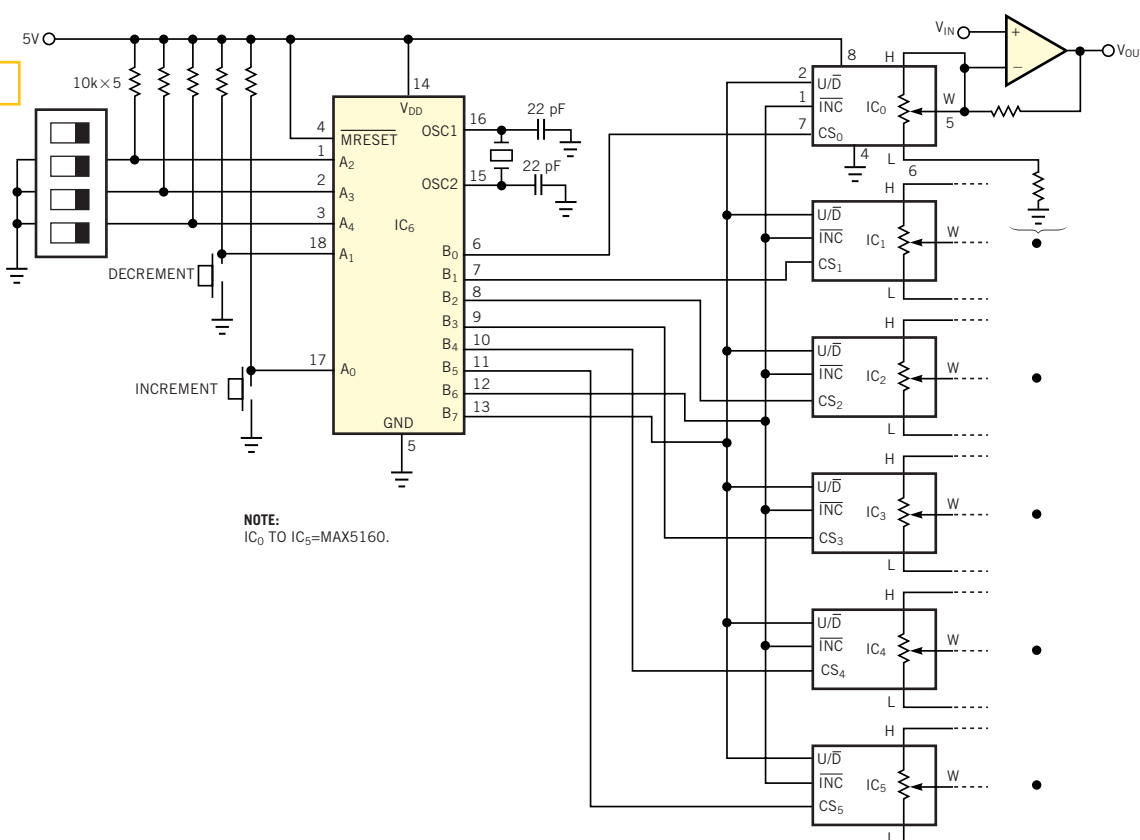

A single μC controls six digital potentiometers.



## Design Idea Entry Blank

Entry blank must accompany all entries. \$100 Cash Award for all published Design Ideas. An additional \$100 Cash Award for the winning design of each issue, determined by vote of readers. Additional \$1500 Cash Award for annual Grand Prize Design, selected among biweekly winners by vote of editors.

To: Design Ideas Editor, EDN Magazine  
275 Washington St, Newton, MA 02458

I hereby submit my Design Ideas entry.

Name \_\_\_\_\_

Title \_\_\_\_\_

Phone \_\_\_\_\_

E-mail \_\_\_\_\_ Fax \_\_\_\_\_

Company \_\_\_\_\_

Address \_\_\_\_\_

Country \_\_\_\_\_ ZIP \_\_\_\_\_

Design Idea Title \_\_\_\_\_

Social Security Number \_\_\_\_\_  
(US authors only)

**Entry blank must accompany all entries.** (A separate entry blank for each author must accompany every entry.) Design entered must be submitted exclusively to *EDN*, must not be patented, and must have no patent pending. Design must be original with author(s), must not have been previously published (limited-distribution house organs excepted), and must have been constructed and tested. Fully annotate all circuit diagrams. Please submit text and listings by e-mail to [b.travis@cahners.com](mailto:b.travis@cahners.com) or send a disk.

Exclusive publishing rights remain with Cahners Publishing Co unless entry is returned to author, or editor gives written permission for publication elsewhere.

In submitting my entry, I agree to abide by the rules of the Design Ideas Program.

Signed \_\_\_\_\_

Date \_\_\_\_\_

**Your vote determines this issue's winner. Vote now, by circling the appropriate number on the reader inquiry card.**